

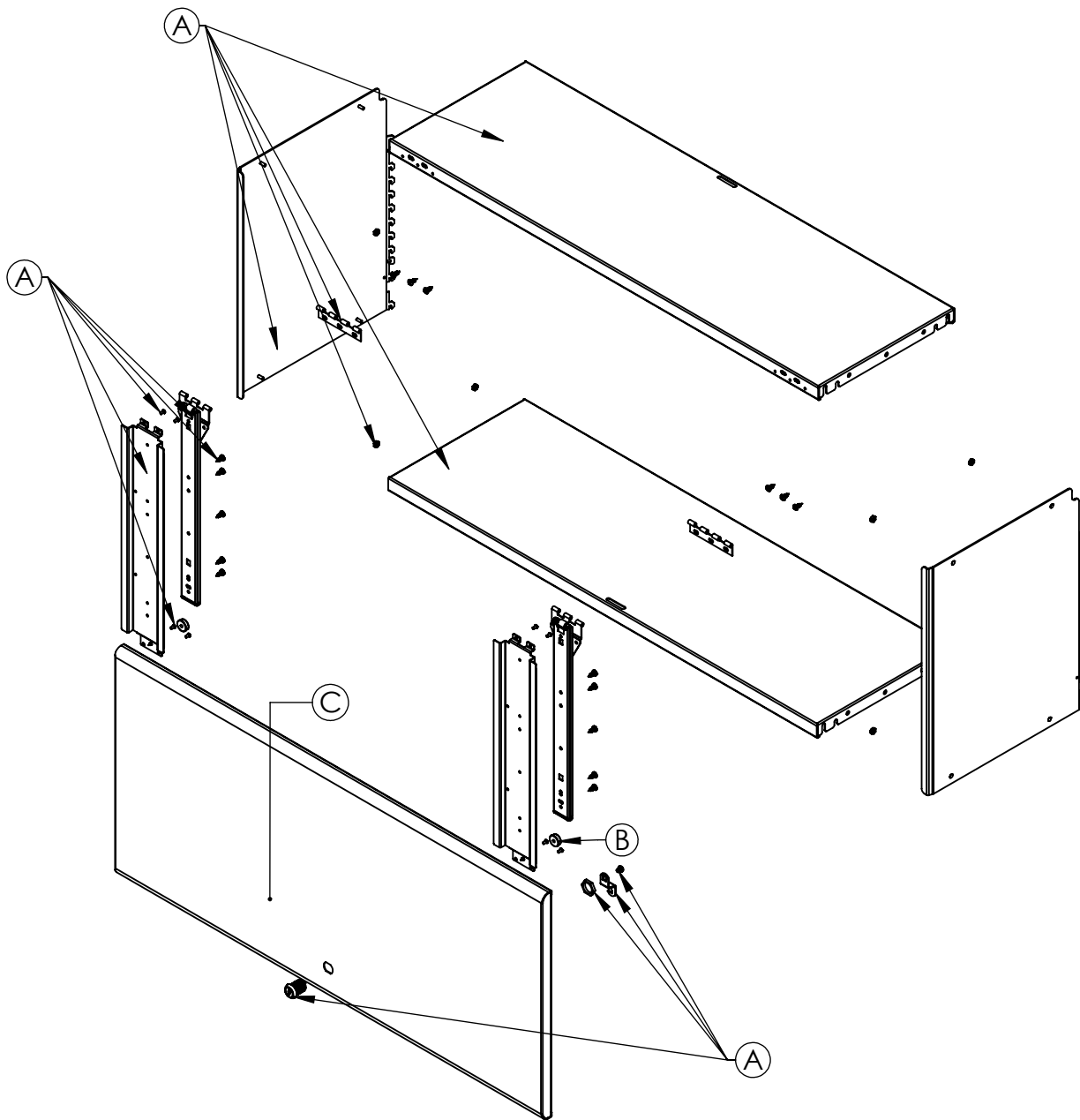



PARTS		SPECS	TOOLS REQUIRED
A.) STEEL		STEEL	1.) CORDLESS DRILL
B.) WOOD		LAMINATED COMPOSITE WOOD	2.) PHILLIPS SCREWDRIVER
C.) PLASTIC		FLEXIBLE PVC	



PARTS	SPECS	TOOLS REQUIRED
A.) STEEL 	STEEL	1.) FLATHEAD SCREWDRIVER
B.) PLASTIC	RUBBER	2.) CORDLESS DRILL
C.) PEDASTAL FACE	1.) STEEL  2.) LAMINATE WITH PLASTIC PVC EDGE	3.) PHILLIPS SCREWDRIVER
		4.) 3/8 WRENCH

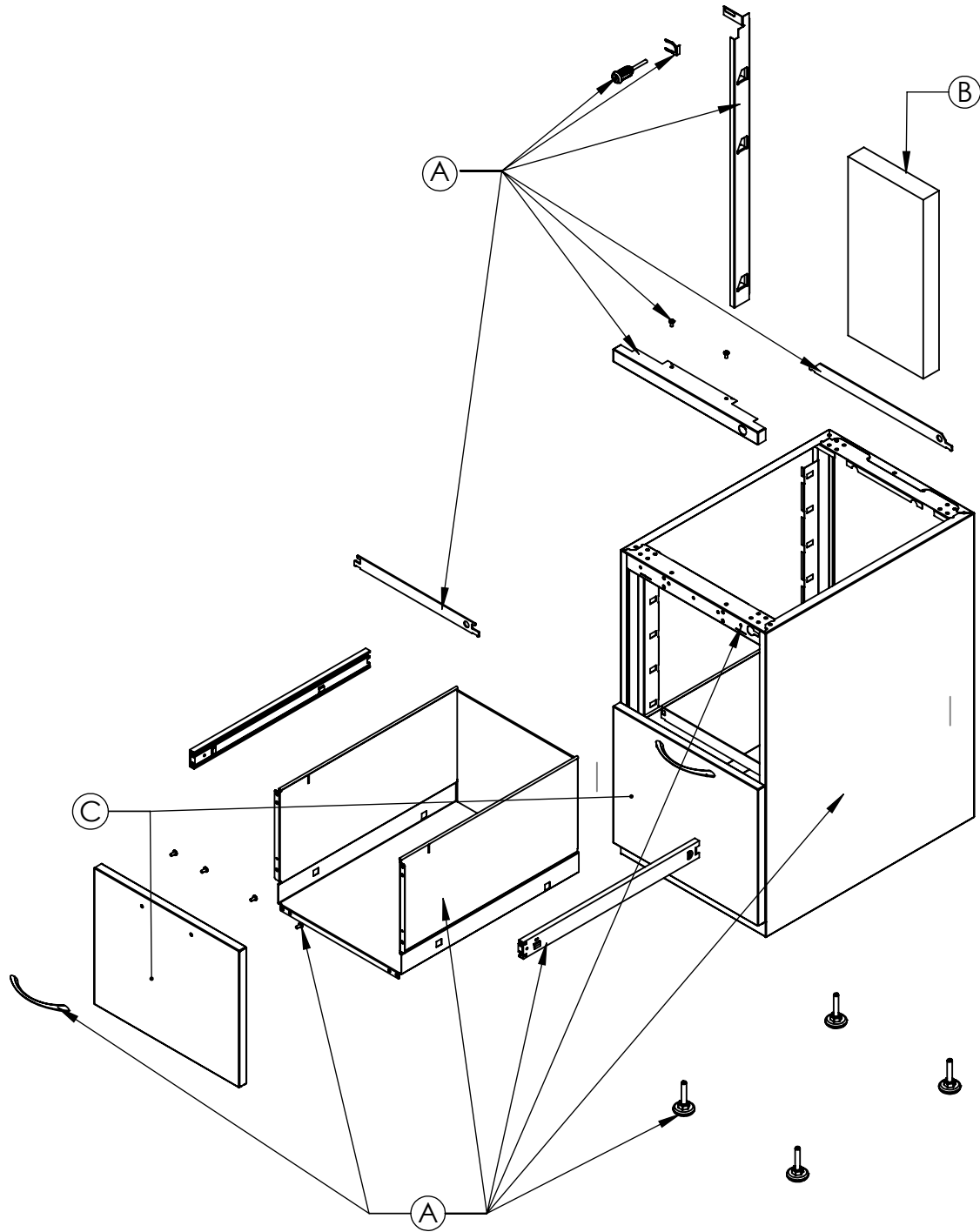

PARTS	SPECS	TOOLS REQUIRED
A) STEEL 	STEEL	1.) FLATHEAD SCREWDRIVER
B.) CEMENT	CEMENT	2.) CORDLESS DRILL
C.) PEDASTAL FACE	1) STEEL  2) LAMINATE WITH PLASTIC PVC EDGE	3.) PHILLIPS SCREWDRIVER