

# Suspended Storage

## Step 1:

Determine the correct Storage Support Brackets for your application.

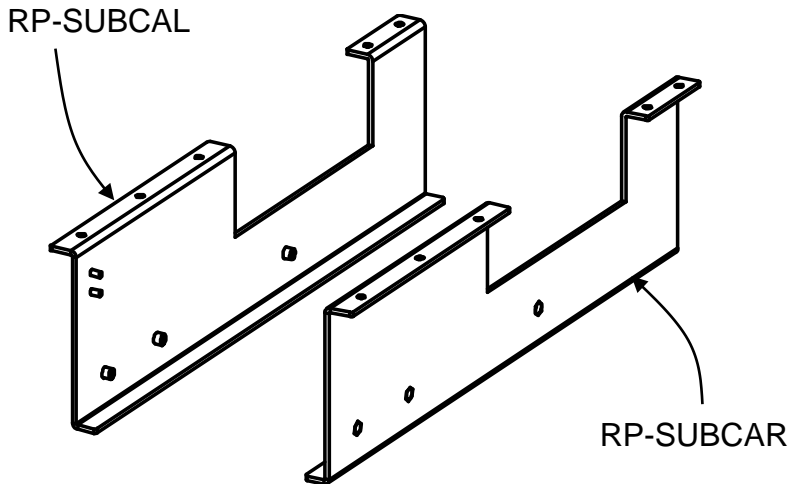

### Condition A:

- Oxygen 30D surfaces
- Aloft 2018 24D surfaces
- Day to Day 24D surfaces

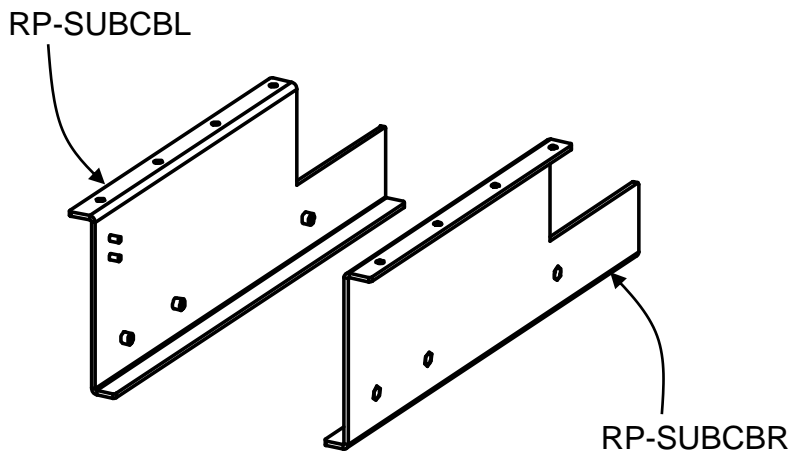

### Condition B:

- Oxygen 24D surfaces
- Aloft 2018 30D surfaces
- Aloft 2019 30D surfaces
- Day to Day 30D surfaces

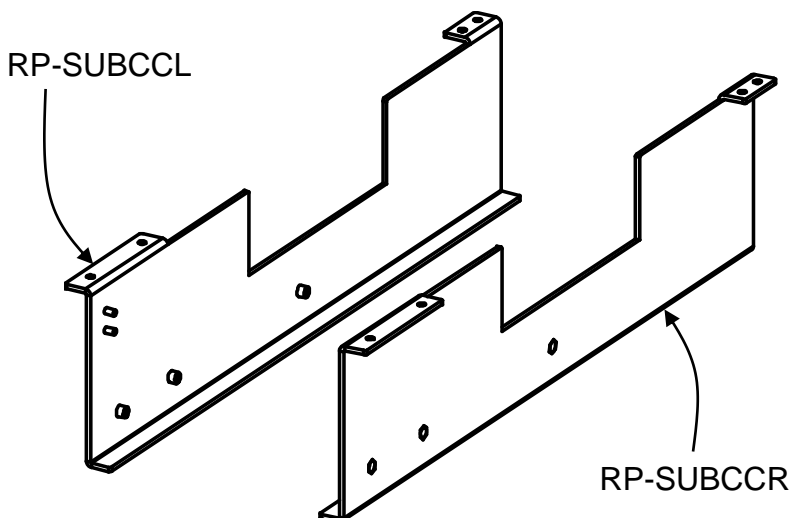

### Condition C:

- Aloft 2019 24D surfaces



The following pages use Condition B as the example. Conditions A and C assemble in the same manner.

# Suspended Storage

## Step 2:

Remove rear slide rails from the storage unit and attach to the Suspended Storage Support Brackets using #8-32 x 1/4" pan head screws.

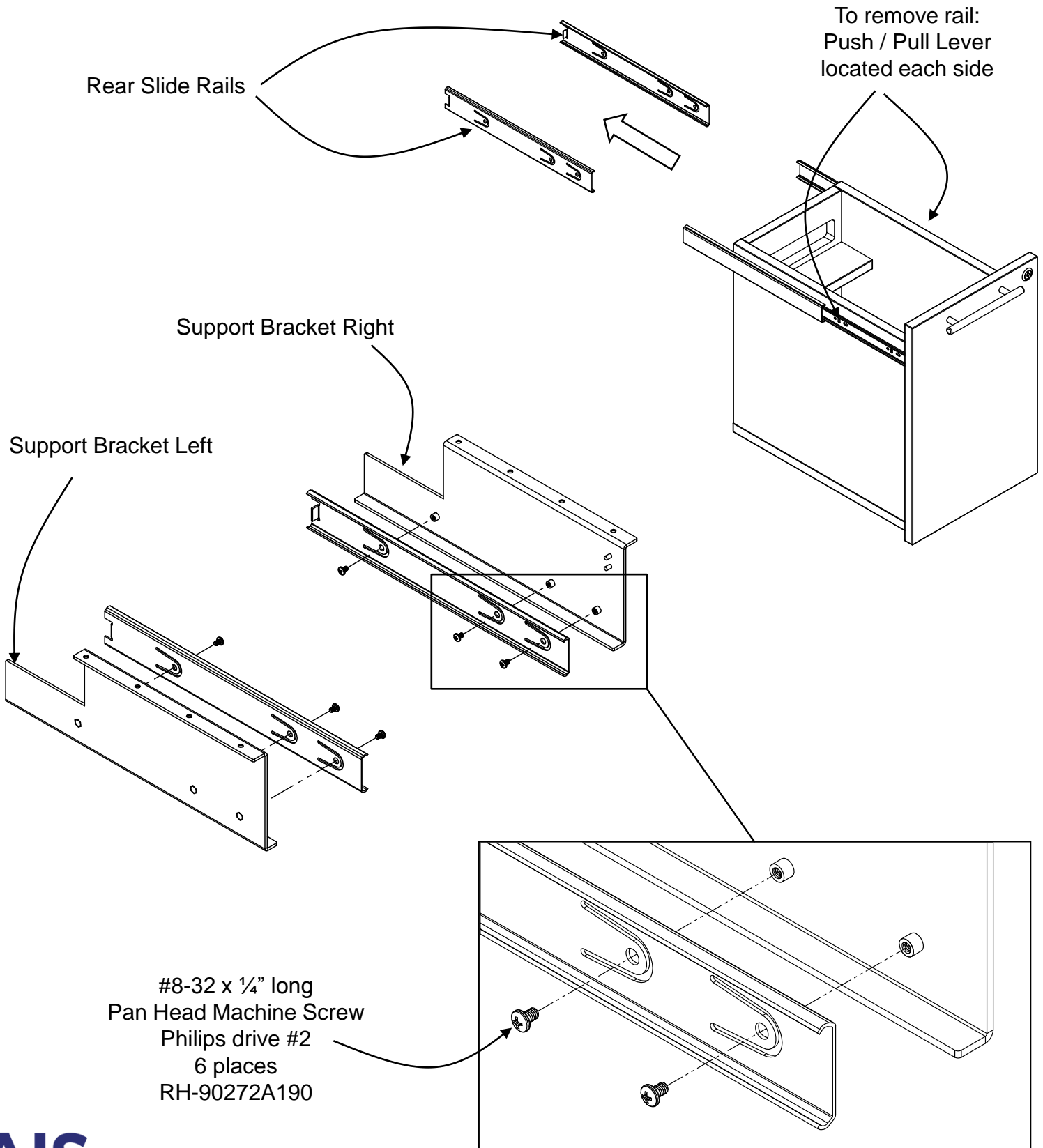

# Suspended Storage

## Step 3:

Install Lock Bracket to Right Support Bracket using 8-32 Hex Nut.

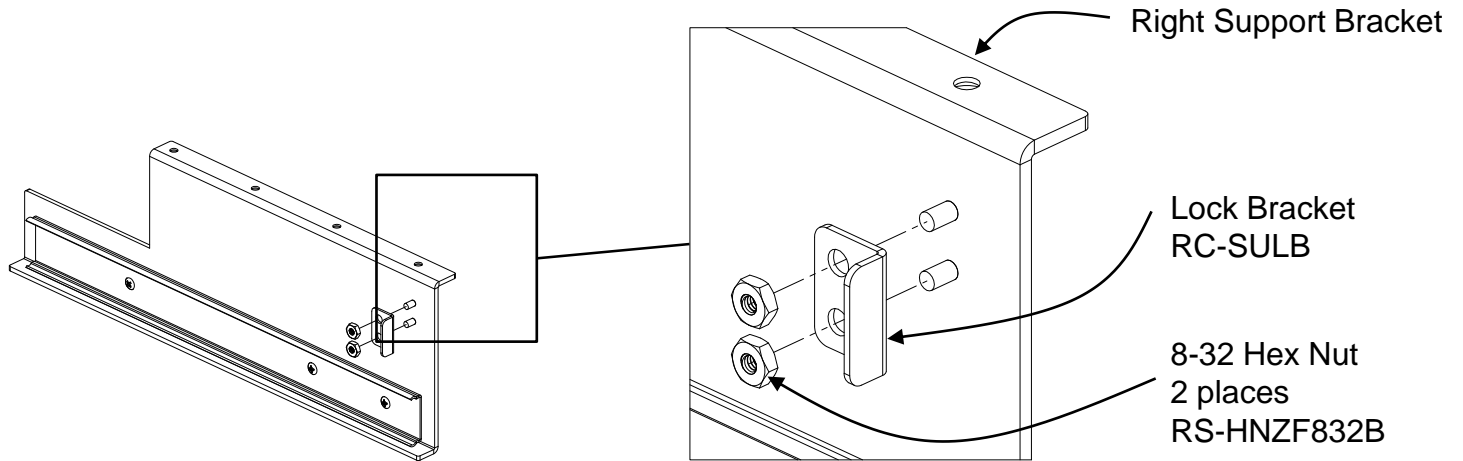

---

## Step 4 (optional):

Install power unit using (2) #6 x 3/8" long screw.

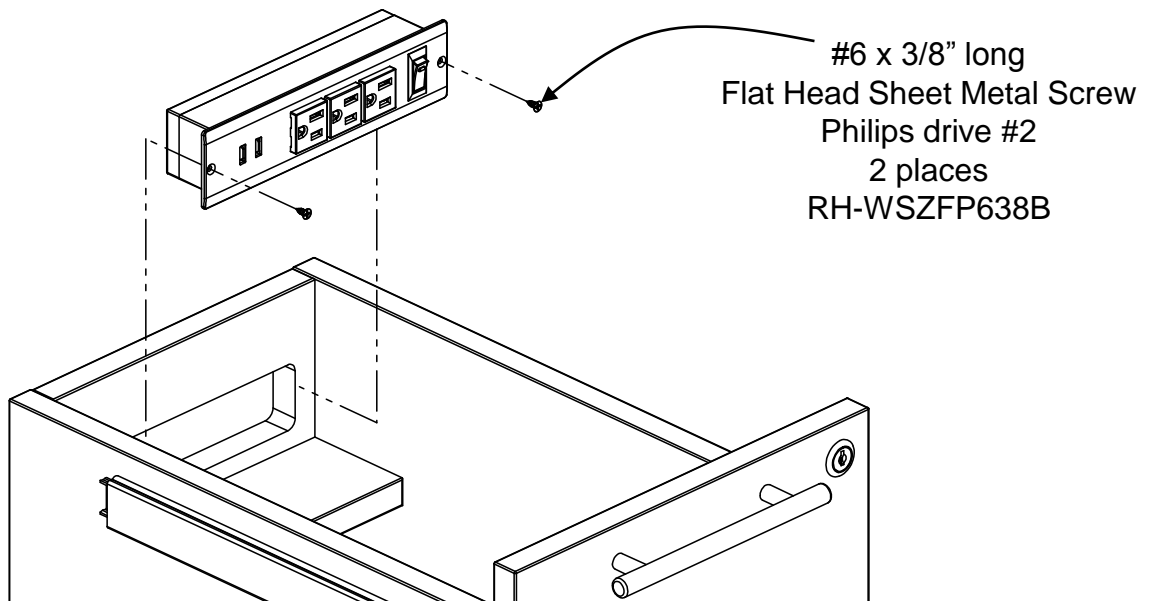

# Suspended Storage

## Step 5 (optional):

Install hanging folder brackets using (4) #8 x 1/2" long screw.

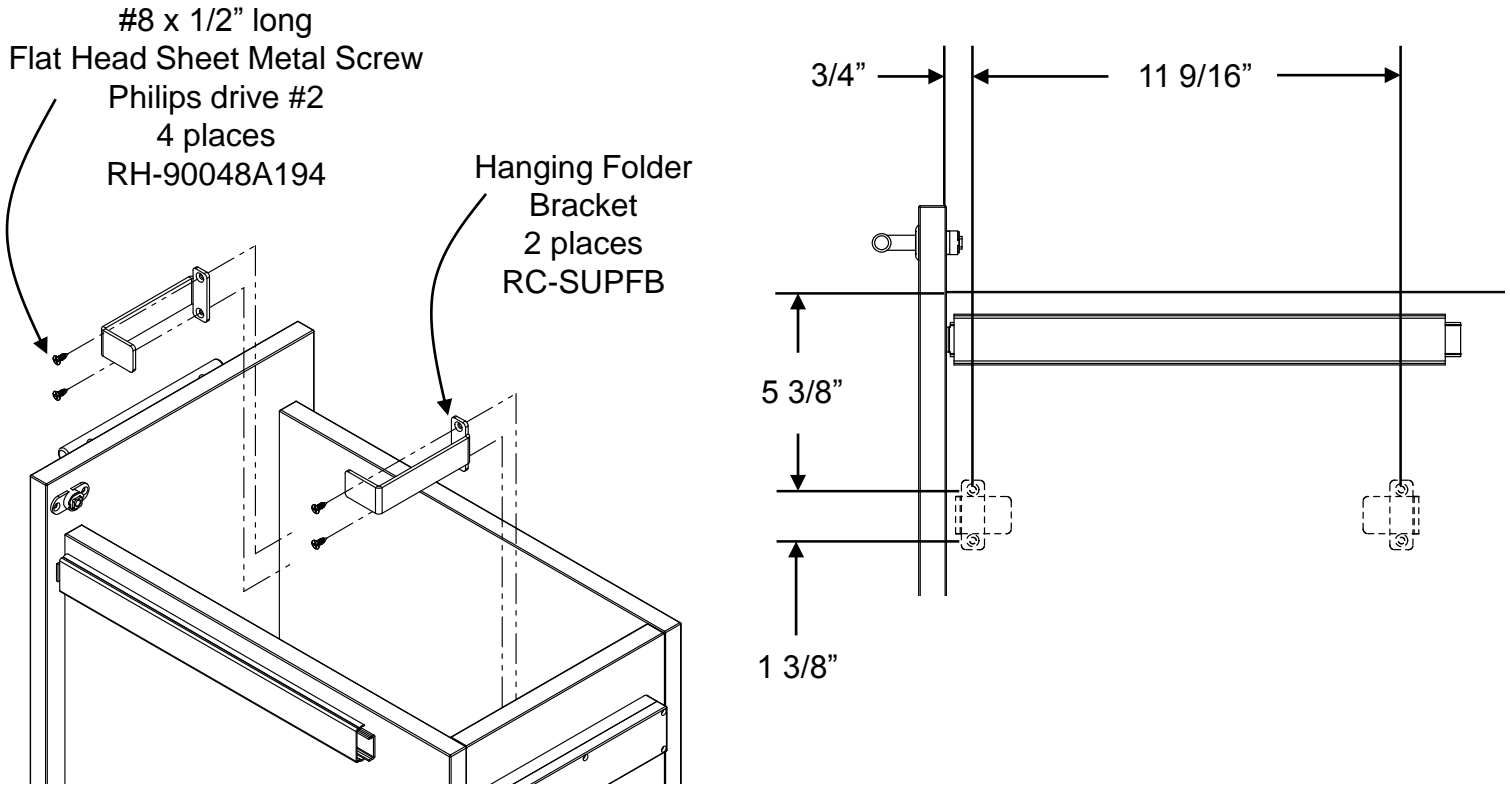

## Step 6:

Re-install both slide rails to storage unit, making sure to push all the way forward to engage.

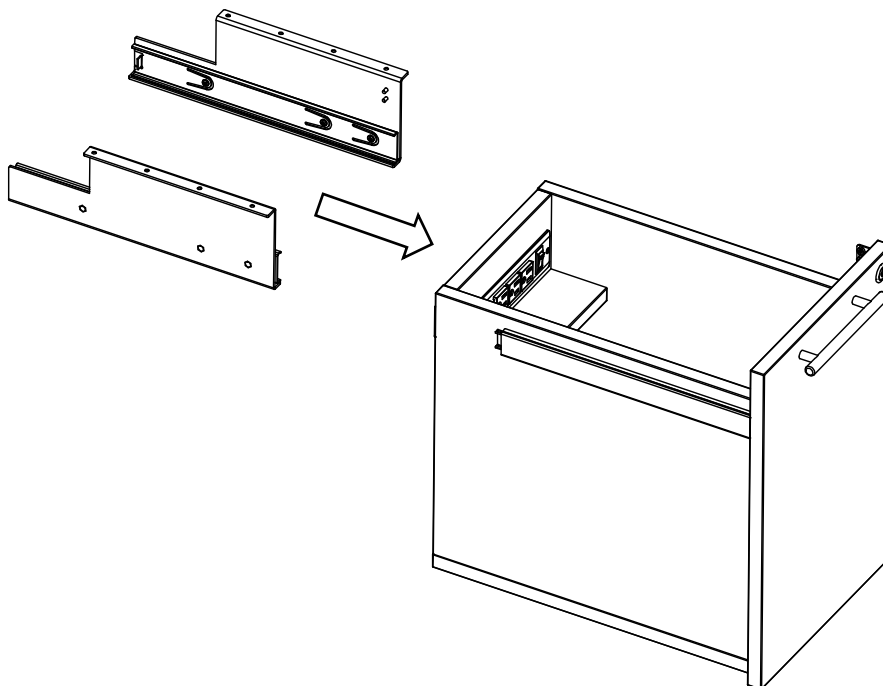

# Suspended Storage

## Step 7:

Attach storage unit to worksurface using #9 x 7/8" screws.

