

# End Panel for Height Adjustable Tables

Date	Page No.	Description of change	Name
02/28/20	All	Released	P. Fortin

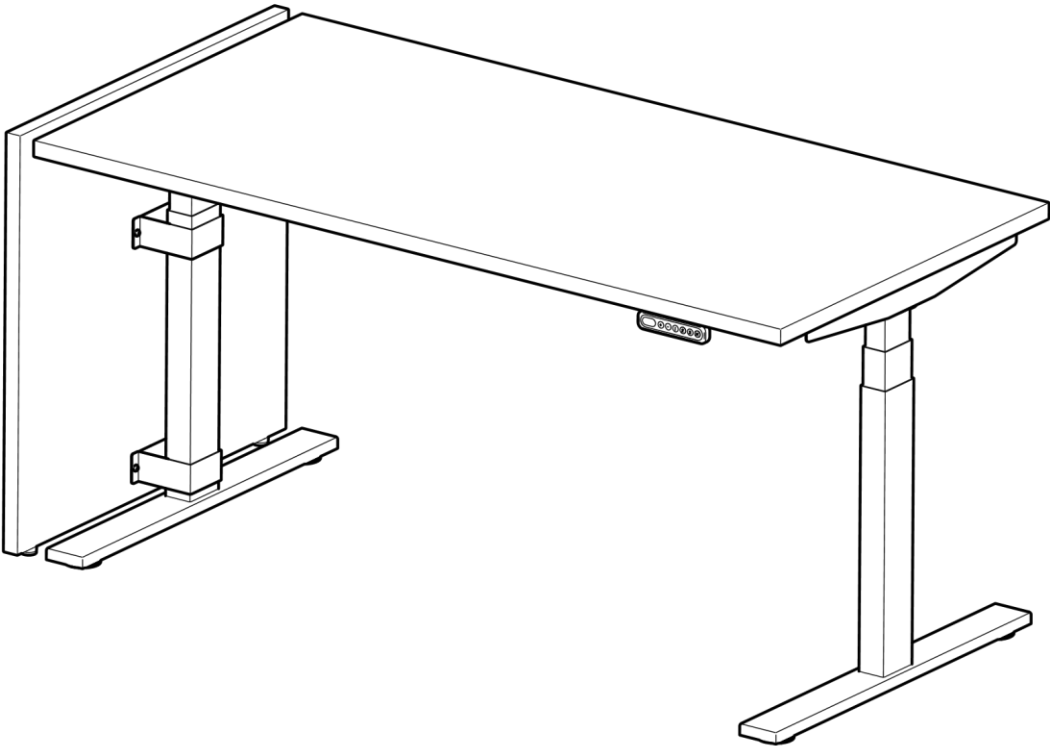

# End Panel for Height Adjustable Tables

Install M6 threaded inserts with metric Allen wrench.

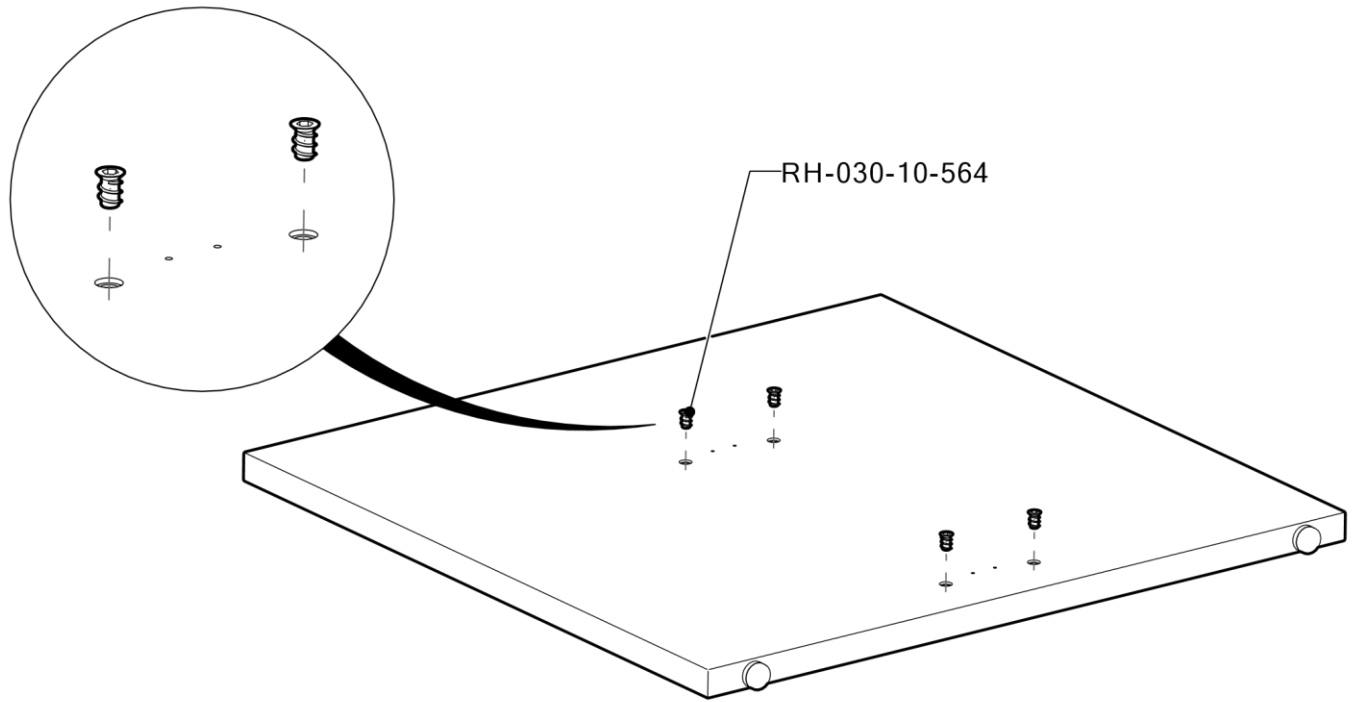

Install End Panel Braces with work surface screws, use the pilot holes provided.

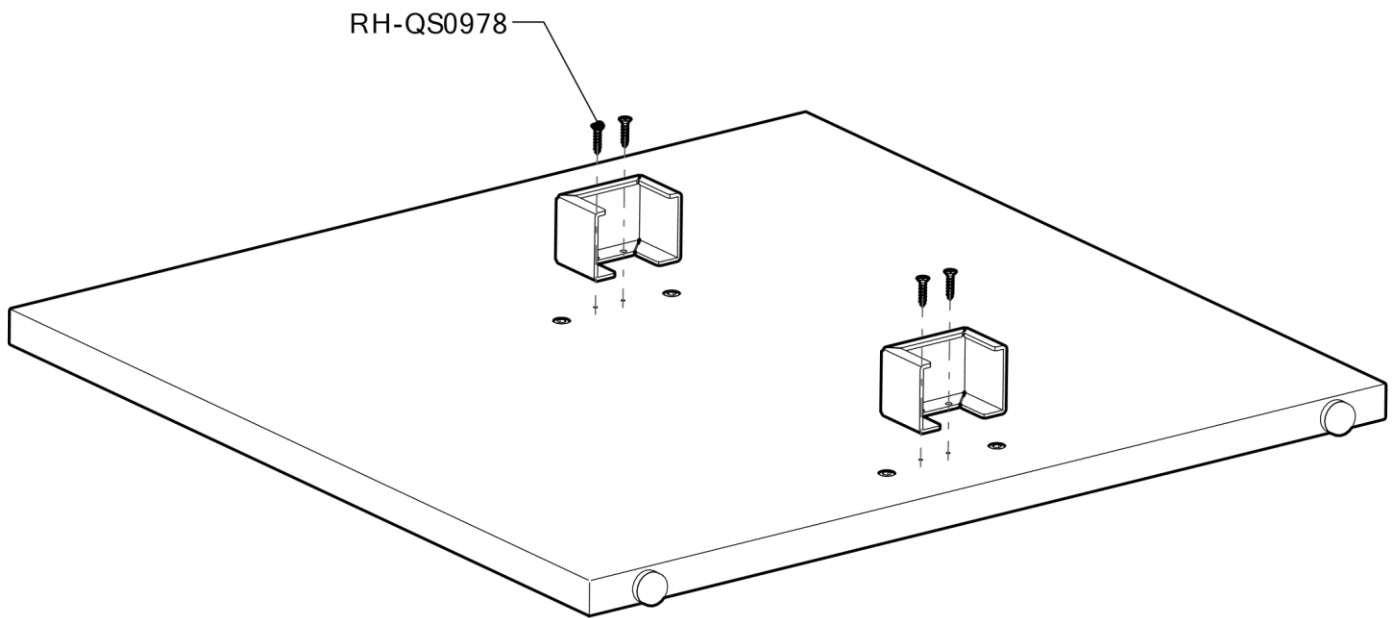

# End Panel for Height Adjustable Tables

If possible, raise the height adjustable table to its upper limit for better access.

Place the partially assembled End Panel against the leg of the height adjustable table.

Inspect the gap between the End Panel and the work surface. There should be a 1" gap for safety along this potential pinch point.

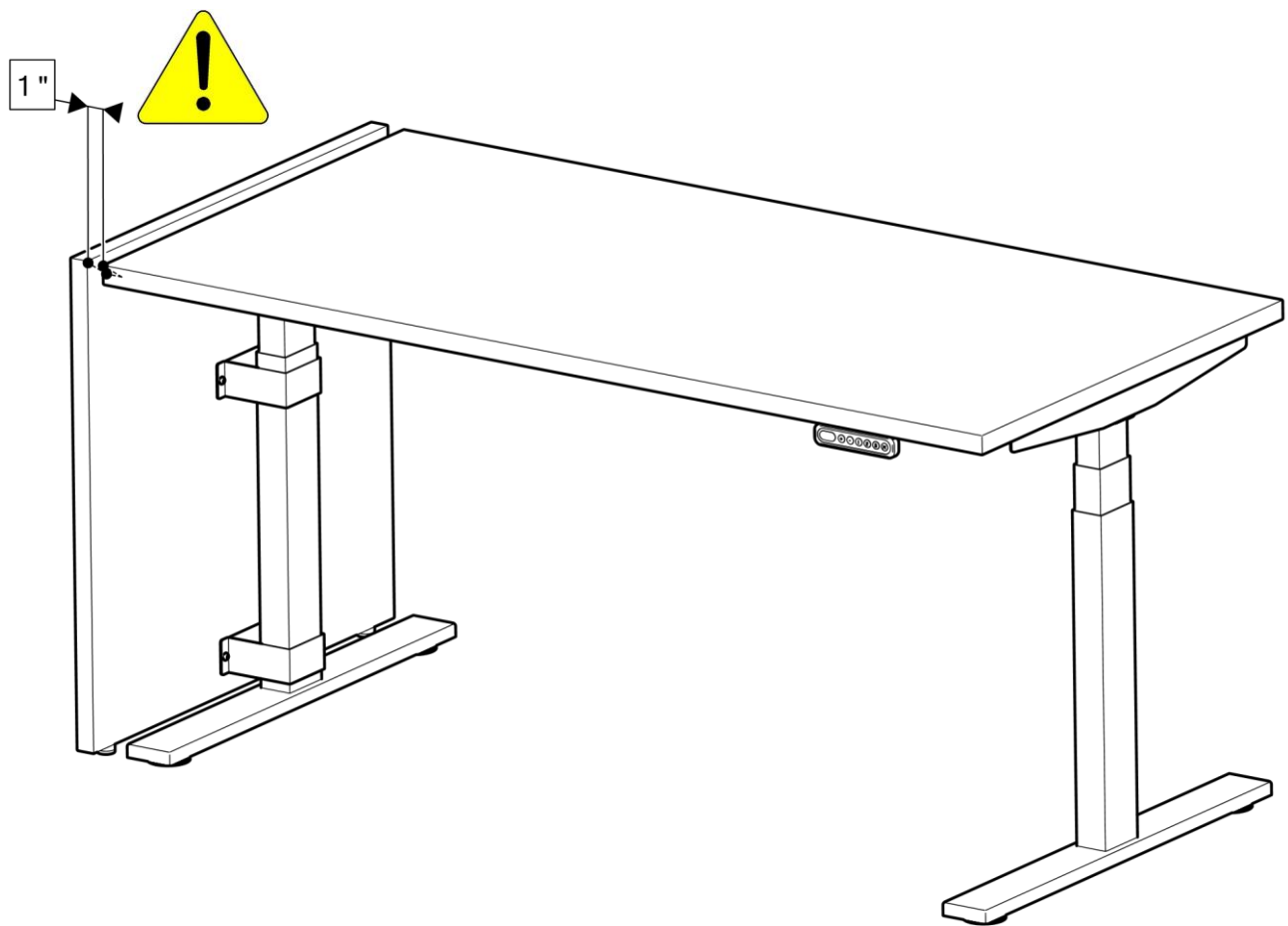

# End Panel for Height Adjustable Tables

Secure the panel to the table leg with (2) U Brackets. Use (4) M6x1x4mm button head cap screws.

